

This paper has been presented at the STAB 2009 conference in St Petersburg. Note that movies are available showing the free trim free twist method and showing the behaviour of the jack-up and semi submersible for the various conditions as given in the paper.

Revision history:

Revision C

-Some small corrections in figure references which did not make it into the final publication

-After publication an error was found in figure 17 where the width of the compartment used for simulating a damage was given as 7 m whilst the results given in figures 22, 23, 24 are for a width of 6 m. A value of 6 m should be used

Revision D

Figure 12, axis, system improved

# The use of energy build up to identify the most critical heeling axis direction for stability calculations for floating offshore structures

Joost van Santen, *GustoMSC, the Netherlands*, [joost.vansanten@gustomsc.com](mailto:joost.vansanten@gustomsc.com)

## ABSTRACT

For offshore structures like semi submersibles and jack-ups, hydrostatic stability is to be determined for what is called the weakest axis, which is not necessarily the same as the longitudinal axis of symmetry of the structure. When allowing trim to take place, the determination of the critical axis is complicated as free trimming leads to multiple solutions regarding the position for a given heel angle. It will be shown that for a freely floating structure, looking at the increase in potential energy can be used to identify those axis directions which are critical as well as realistic. The theoretical results will be illustrated with detailed data obtained for a two typical offshore structures using a standard stability program.

**Keywords:** *offshore, stability, energy, trim, twist*

## 1. INTRODUCTION

Historically, determination of the stability offshore rigs is seen as extension of stability for ships. For ships the longitudinal axis is taken as the heeling axis, where trim is allowed to remove the trimming moment.

Early on, the offshore industry has recognized that the most critical axis is not necessarily the longitudinal axis. So, the wording critical axis was introduced, but as a kind of heritage one also had to consider free trim. This directly leads to a problem.

This problem is that a given position can be defined by infinite combinations of axis directions, heel angle and trim. Two angles suffice to uniquely define the position. Using three angles means that one is superfluous.

In the 80's several papers appeared introducing the use of pressure integration to replace the conventional way of slicing up the structure and calculation of the contribution of each slice, (Witz and Patel, 1985, van Santen,

1986). In the publication of van Santen (1986), the problems mentioned above were raised and a way to avoid them by using free twist was introduced. More recently (Breuer and Sjölund, 2006), the problem was looked at again and using the build up of energy was proposed as a solution.

In the underlying publication, the increase in potential energy of a structure due to forced heel with and without trim will be looked at and examples will be shown.

This paper deals with freely floating structures. Effects due to mooring or dynamic positioning are specifically excluded.

## 2. EXAMPLE WITH A BARGE

For a rectangular barge (figure 1) with a raised forecastle, we can construct the righting arm curves for a range of axis directions (without trim) as shown in figure 2.

Applying free trim has dramatic consequences as is shown in figure 3. For some axis directions the righting arm curves stop prematurely. Why is this? In order to analyze this, the trimming moment as a function of trim angle is to be studied, see figure 4. The trim angle for which this moment is zero is the free trim angle belonging to a particular heeled situation.

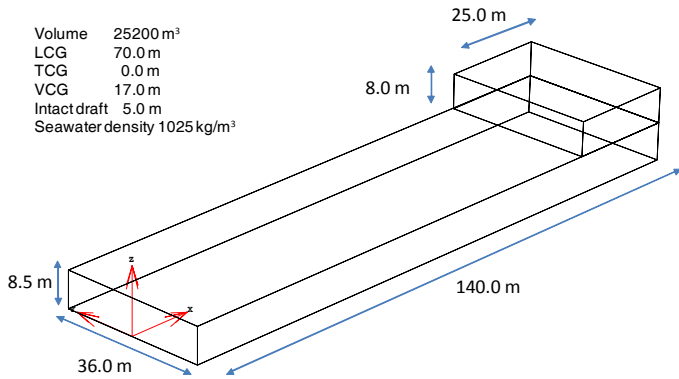

Figure 1 Barge dimensions

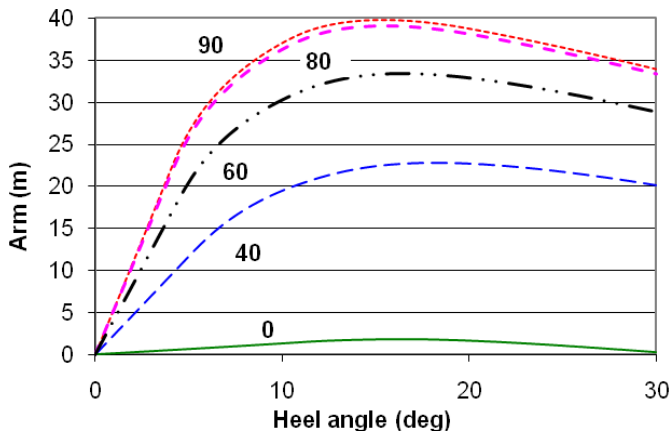

Figure 2 Righting arm curves, no trim

For an axis direction of 80 deg, when heeled beyond 5.6 deg heel, the zero crossings disappear, meaning that there are no solutions with zero trim moment. When passing a certain position, continuation of the righting arm curve can only be achieved by reducing the heel whilst at the same time increasing the trim angle. This leads to the righting arm curve as shown in figure 5 and the trim angle as shown in figure 6.

For intact offshore rigs, some authorities require a range of positive stability of 30 (or

36) deg. For a longitudinal axis direction this criterion would be met, but for an axis direction

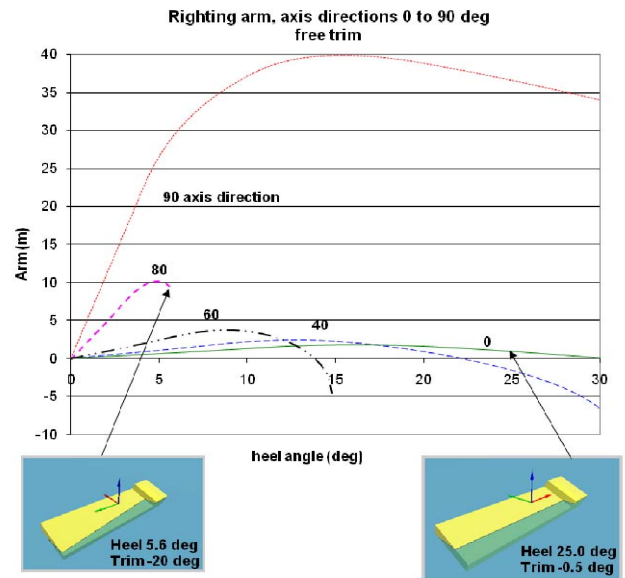

Figure 3 Righting arm curves, free trim

Trimming arm for an axis direction of 80 deg zero value indicates a free trim position

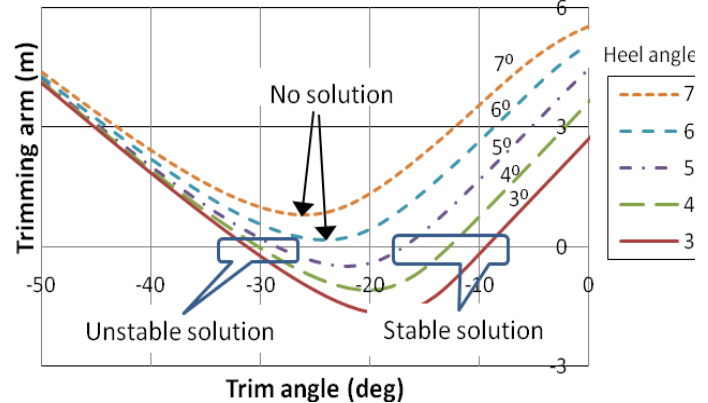

Figure 4 Trimming arm curves

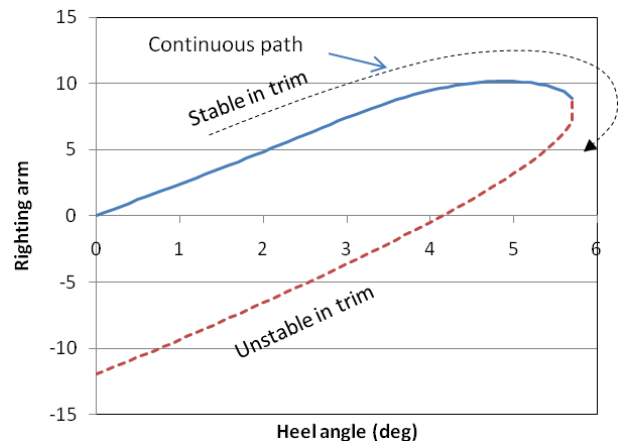

Figure 5 Continuous righting arm curves, free trim

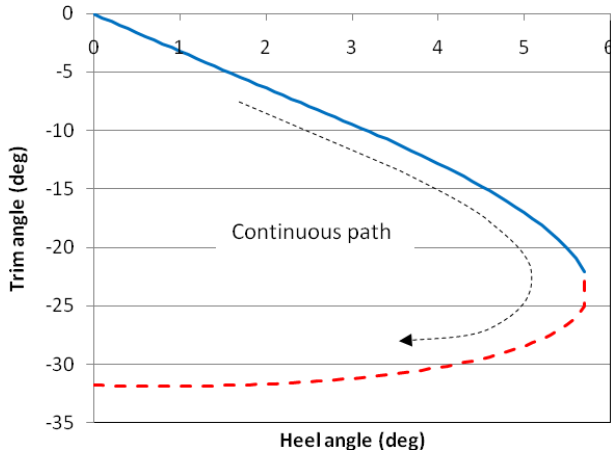

Figure 6 Trim angle for continuous heel

of 80 deg, the structure would fail. So, one could say that 80 deg axis direction is the most critical one and the rig would fail to comply with the range requirement.

Looking at the structure (figure 1) it is obvious that one should select an almost longitudinal axis as the most critical axis direction and not 80 deg. But for a more generic structure it is not that easy to identify the critical axis direction.

Why is it that from visual observations we reject 80 deg and accept 0 deg ? The key can be found in the rate at which the potential energy in the system increases with heel. For 0 deg axis direction this is far less than for 80 deg.

The potential energy is given by the negative of the vertical distance (VCB) between the centre of gravity CoG and the centre of buoyancy CoB.

$$\text{Energy} = -\text{VCB} \times \text{displacement}, \text{ where} \quad (1)$$

E will be used to denote energy divided by displacement, so  $E = -\text{VCB}$ .

At the equilibrium position the energy is taken as the reference value,  $E_0$ . For a change in heel, the increase in energy is given as

$$\begin{aligned} \Delta E &= E(\varphi) - E_0 \\ &= \text{VCB}_0 - \text{VCB}(\varphi) \end{aligned} \quad (2)$$

The input of energy is the work done by the overturning heeling moment given by

$$\int_0^\varphi M(\varphi) d\varphi \quad (3)$$

Where  $M(\varphi)$  is the overturning moment divided by displacement. This results in:

$$\begin{aligned} -(\text{VCB}(\varphi) - \text{VCB}_0) &= \int_0^\varphi M(\varphi) d\varphi \\ &= \int_0^\varphi -(\text{righting arm}) \times d\varphi \end{aligned} \quad (4)$$

Note that for a free floating structure, a positive overturning moment results in a positive righting arm, but this means in fact that the counteracting restoring moment given by  $y_{\text{cob}}$  is negative.

The most critical axis can be viewed as the axis direction for which a given heel angle is reached with the least effort. In this way, the least energy is to be fed into the system in order to reach that particular heel angle.

Figure 7 shows the amount of energy fed into the barge depending on axis direction and heel angle.

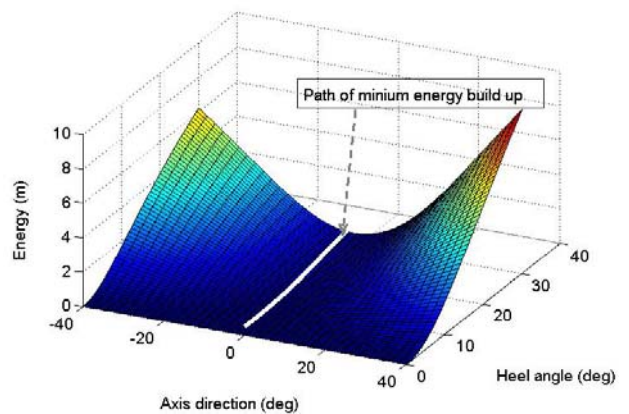

Figure 7 Energy surface for the barge

The trim is fixed to zero. From this figure it is seen that for an axis direction of about 0 deg the lowest amount of energy is needed to reach a given heel angle. This agrees with the subjective feeling that the most critical axis is almost longitudinal.

The problem now is how to determine the axis direction for which the energy increase is lowest. But before we do so, another example will be given, as found in the publication by Breuer and Sjöland (2006).

### 3. ABS JACK-UP

Following discussions between MSC and ABS on the approval of a particular MSC jack-up, related to the Range of Stability (RoS) requirement (ABS rules 2008), Breuer and Sjöland (2006) published their paper in which they showed energy contour plots for a range of trim and heel angles.

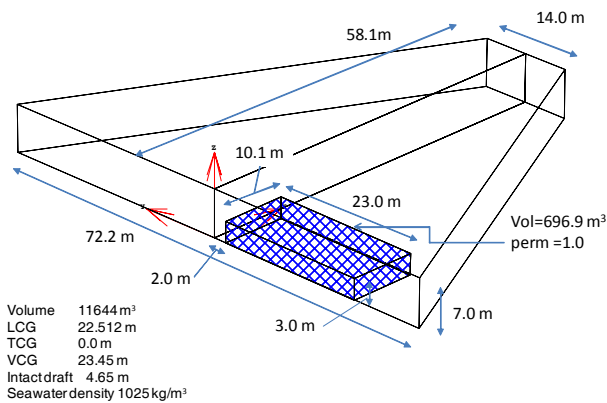

Figure 8 Dimensions of the studied jack up

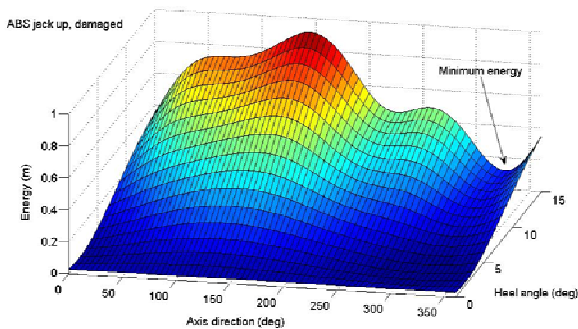

Figure 9 Energy surface of the studied jack up, damaged condition

For the damage as indicated in figure 8, the increase in energy depending on axis direction and heel angle is given in figure 9.

This shows that the lowest rate of increase is found for an axis direction of about 320 deg. For this direction, the righting arm is shown in figure 10 (free trim). Selecting another axis direction (280 deg) results in a vanishing righting arm curve, as shown in figure 11. Note the large trim angles related to the vanishing arm curve. Using an axis direction of 280 deg may lead to the false impression that the RoS criterion is not. Actually it is met, but it is for an axis direction of 320 deg.

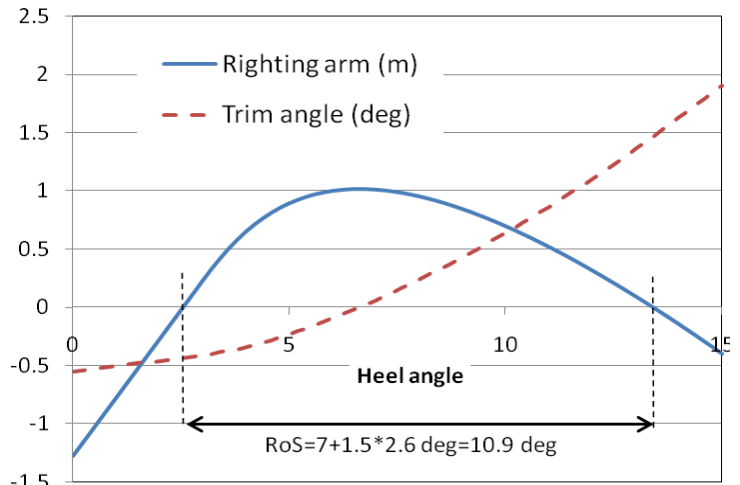

Figure 10 Righting arm and trim angle, axis direction 320 deg

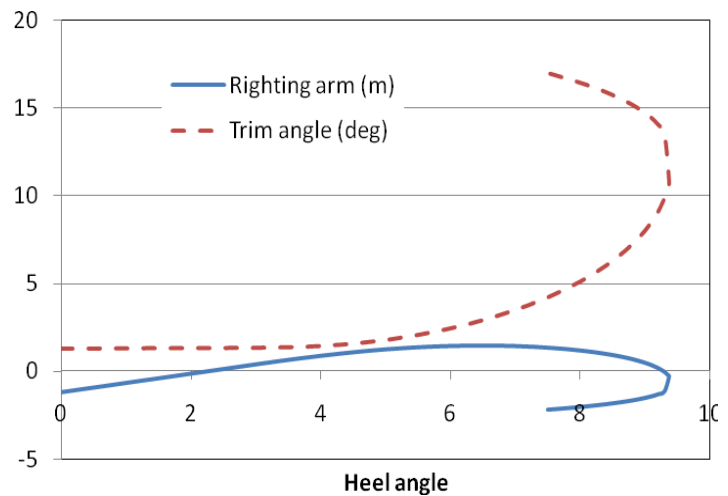

Figure 11 Righting arm and trim angle, axis direction 280 deg

4. AXIS CONVENTION

When using heel, trim and twist, it is important to have a clear understanding of their meaning. For the remainder of this publication, the following convention is used when positioning a structure in a heeled condition (see figure 12):

- first the heeling axis direction is chosen,
- the structure is heeled around this axis
- the structure is trimmed around a transverse axis which was initially horizontal but changes direction due to heel.

5. FREE TRIM VERSUS FREE TWIST

As is seen above, looking at energy increase during heel is a clear indicator for the determination of the critical axis direction. The next question is how to deal with trim. For ships, introducing free trim is clearly meant to obtain the lowest righting arm. This is easily seen when going from the free trim to the situation with nil trim. When going from the trimmed to the free trim situation, energy is dissipated, thus the righting arm is less than for the fixed axis direction and zero trim situation. The question is if this also works when varying the axis direction.

For this purpose consider a heeled position with both a zero trimming moment and a zero moment around the twist axis which is the initially vertical axis. When applying a small change in the trim angle ( $d\theta$ ) and in the axis direction ( $d\psi$ ) reactive moments will result.

For a constant displacement, using conventional hydrostatic considerations, these moments can be determined by looking at the horizontal and vertical components of the rotations. The horizontal component ( $\alpha$ ) causes a change in waterline shape and in CoB position. The combined effect translates into a reactive moment  $-GM_L \alpha$ .

The rotation ( $\beta$ ) around the vertical axis causes a transverse movement of the CoB

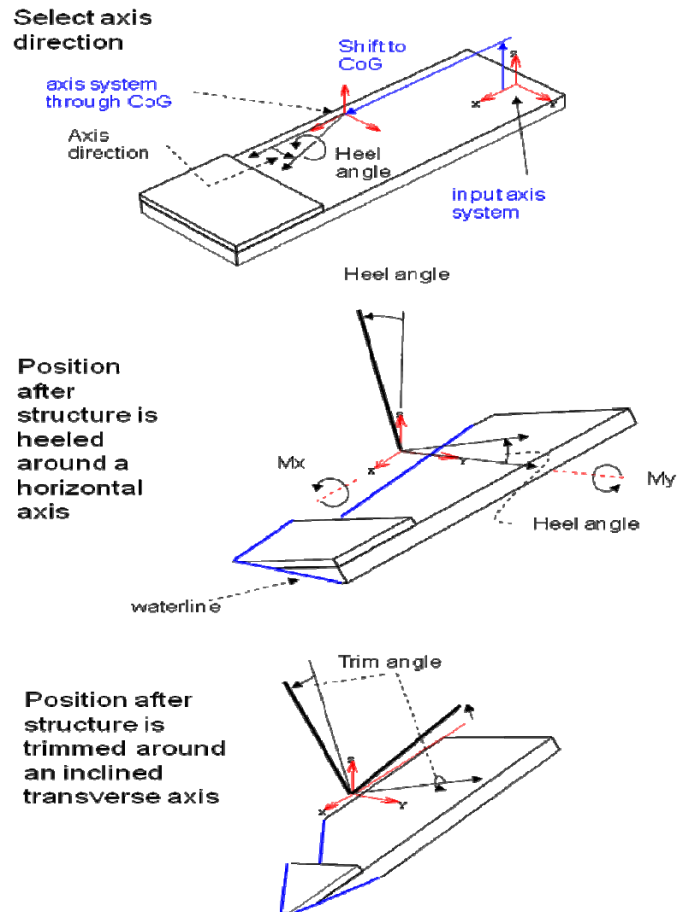

Figure 12 Application of twist, heel and trim

which causes a reactive moment  $y_{cob} \beta$ . Thus, for a change of trim,  $d\theta$ , the externally imposed moment needed for this change in trim becomes:

$$My_t = (GM_L \cos \varphi - y_{cob} \sin \varphi) d\theta \tag{5}$$

Note that the value of GM is the instantaneous metacentric height for the given heeled position.

Similarly, due to a change of axis direction  $d\psi$  the externally imposed moment becomes:

$$My_a = (-GM_L \sin \varphi - y_{cob} \cos \varphi) d\psi \tag{6}$$

These moments are around a horizontal axis. When considering energy input, the moment is to be taken along the axis around which the rotation takes place. For instance, for

trim, the moment around the trim axis is  $My_a \cos \phi$ . Thus, for trim the energy input starting from the free twist, zero trim, position is:

$$dE_t = \frac{1}{2} \cos \phi (GM_L \cos \phi - y_{cob} \sin \phi) d\theta^2 \quad (7)$$

Due to a change in axis direction the energy input starting from free twist is:

$$dE_a = \frac{1}{2} \sin \phi (GM_L \sin \phi + y_{cob} \cos \phi) d\psi^2 \quad (8)$$

The term between the brackets in equation 7 is in general positive. In equation 8, for small heel angles the term between the brackets can be approximated by  $GM_L \phi - GM_T \phi \cos \phi$ . So, for small heel angles, it is in general small but also positive. For larger angles it is in general positive. So, in general, when starting from the free twist position with zero trim and applying either a small change in twist or in trim an increase in energy in the system is found. Thus, the free twist position is the position with the lowest potential energy for a given heel angle.

The question arises if there is a reduction in energy when going from a free twist position with zero trim to a new position (with a change in twist of  $d\psi$ ) and letting the rig free to trim with angle  $d\theta$ . The energy input needed to twist is given by  $dE_a$ . By letting the rig free to trim, the energy recovered is  $-dE_t$ . So the total energy input is  $dE_a - dE_t$ . The twist angle is obtained by imposing a moment on the rig. This moment is nullified by letting it free to trim. So:

$$My_a = -My_t \quad (9)$$

Using equations 5 and 6 gives the relation between  $d\psi$  and  $d\theta$ :

$$d\psi = \frac{GM_L \cos \phi - y_{cob} \sin \phi}{GM_L \sin \phi + y_{cob} \cos \phi} \cdot d\theta \quad (10)$$

By substituting [10] in [8] the difference in energy input is found to be

$$dE = dE_a - dE_t \quad (11)$$

$$= -\frac{1}{2} d\theta^2 y_{cob} \frac{GM_L \cos \phi - y_{cob} \sin \phi}{GM_L \sin \phi + y_{cob} \cos \phi}$$

Generally, the following applies:

- $GM_L$  is positive,
- $y_{cob}$  is negative for a positive righting arm

Thus, for the weakest axis, the numerator  $GM_L \cos \phi - y_{cob} \sin \phi$  is in general positive. The denominator is also in general positive. So, when going from a free twist to a free trim situation the energy input is positive. This leads to the conclusion that the free twist situation contains less energy than fixing the axis direction combined with free trim. The free twist position equals the situation with a local minimum energy as both moments  $My_t$  and  $My_a$  are zero.

For the jack-up show in figure 8, the numerical values for small variations in trim and twist around the free twist point are shown in figure 13. These are based on the calculations with a stability program as well as on the approximations given above.

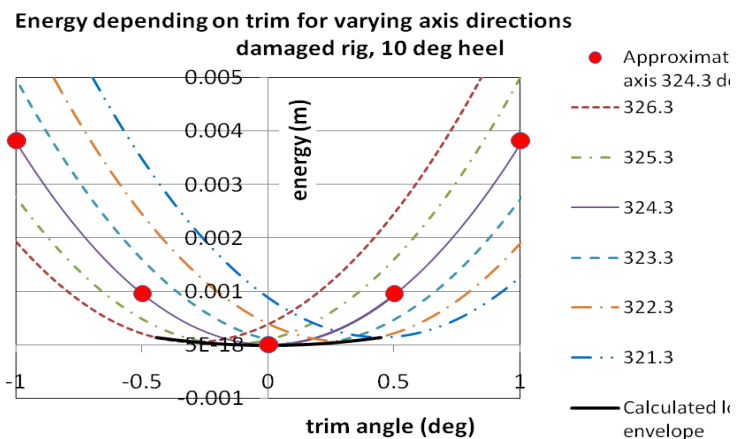

Figure 13 Energy depending on trim

Also, the calculated relation according to equation [10] between axis and trim for which energy  $E_a$  is exchanged with  $E_t$  is shown (“lowest envelope”). This figure shows the validity of the theoretical formulations.

It is important to be aware that in the free twist method, trim is always zero. Hence, the heel angle is always equal to the steepest slope of an initial horizontal plane (like a deck).

### 6. CHANGE IN AXIS DIRECTION DUE TO A CHANGE IN HEEL ANGLE

In section 5 it is shown that the free twist method results in the lowest amount of potential energy build up for a given heel angle.

For a free twist situation, the moment around the initial vertical axis is zero. When making a small step in the heel angle, the change in axis direction can be estimated using this condition. For a constant displacement a heel increase  $d\phi$  results in moment around the twist axis of  $-C_{xy} \cdot d\phi$ , where  $C_{xy}$  = cross moment of inertia of the waterline for a rotation around its centre of floatation. Making this equal but opposite to the moment due to a small change in twist ( $My_a$ , equation [6]) the change in axis direction results

$$d\psi = \frac{-C_{xy} / \text{volume}}{GM_L \sin \phi + y_{cob} \cos \phi} d\phi \quad (12)$$

It is seen that the axis direction is influenced by both the metacentric height ( $GM_L$ ) and the righting arm (which equals  $-y_{cob}$ ).

### 7. STABILITY OF THE SOLUTION

The free twist position is characterized by the twist moment  $My_a$  being zero. It is not necessarily a position with the lowest energy, but it can also be a position with the highest energy. For a given heel angle, there are

several axis directions for which the energy is either minimum or maximum. The maximum is by definition an unstable position, the minimum is a stable position. Stability is indicated by the energy input equations 8 (for twist) and 7 (for trim). If the term  $GM_L \sin \phi + y_{cob} \cos \phi$  is negative, the position is unstable in twist. For an intact structure at a small heel angle, the following approximations apply:

$$\begin{aligned} y_{cob} &= -GM_t \phi \\ \sin(\phi) &= \phi \\ \cos(\phi) &= 1.0 \\ \text{stability term :} & \\ (GM_L - GM_t)\phi & \end{aligned} \quad (13)$$

Clearly, for small angles the position is stable when heeling is around the axis with the smallest GM value. For larger angles, the actual values of  $GM_L$  and  $y_{cob}$  are to be considered.

When the structure is in free to trim, also the stability for trim should be looked at. For trim to be unstable, the term  $GM_L \cos \phi - y_{cob} \sin \phi$  is to be negative. Keeping in mind that  $-y_{cob}$  is the righting arm, it is seen that for a positive righting arm this is the case as long as  $GM_L$ , being the metacentric height for the given heeled position, is positive.

### 8. CASE STUDIES

For two structures, analyses have been done into the increase in potential energy during progressive heeling. These structures are:

- ABS jack-up,
- a simplified semi submersible

#### 8.1 ABS jack-up

**Intact.** This structure, see fig 8, has been analyzed for both the intact and damaged condition. For the intact condition, figure 14 shows the energy surface for a range of heel

angles (0-24 deg) and a range of axis directions (0-360 deg).

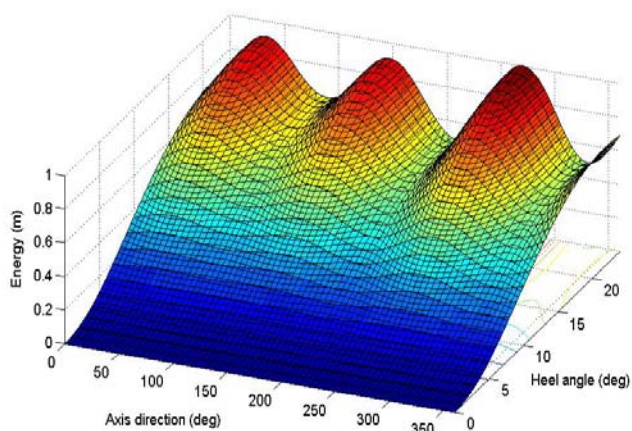

Figure 14 Energy surface intact

It is seen that for larger heel angles 3 axis directions are present following the local minimum path. These are 90<sup>0</sup>, 210<sup>0</sup> and 330<sup>0</sup>. The 210 and 330 deg directions are in fact identical due to the symmetry of the structure.

From the graph, it is also seen that the 330 (or 210) degree yields the lowest energy increase. For angles exceeding about 6 degrees heel there are 3 maxima and 3 minima in the plot. What is not clear is that for smaller heel angles there are only 2 maxima and 2 minima. The extremes at around 35 deg and 145 deg disappear for small heel angles. This is shown in figure 15 which shows the axis directions which have a zero twist moment depending on the heel angle.

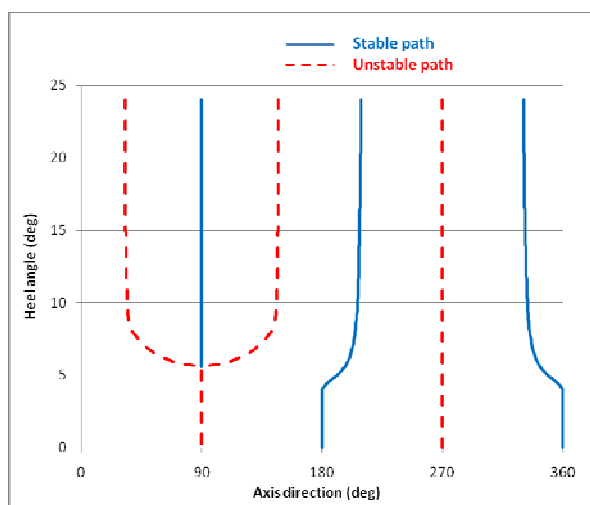

Figure 15 Axis directions for minimum energy build up, intact

**Damaged.** The damage case has a damaged compartment as indicated in figure 8. For a VCG of 23.45 m, the range of stability criterion of ABS is just met. This range should be 7 deg + 1.5 x steady heel (2.59 deg) = 10.89 deg.

The plot of the energy (figure 9) shows a minimum value for an axis direction of around 320 deg. Figure 16 shows the axis direction for which free twist is satisfied, i.e. where the moment around the y axis is indeed zero.

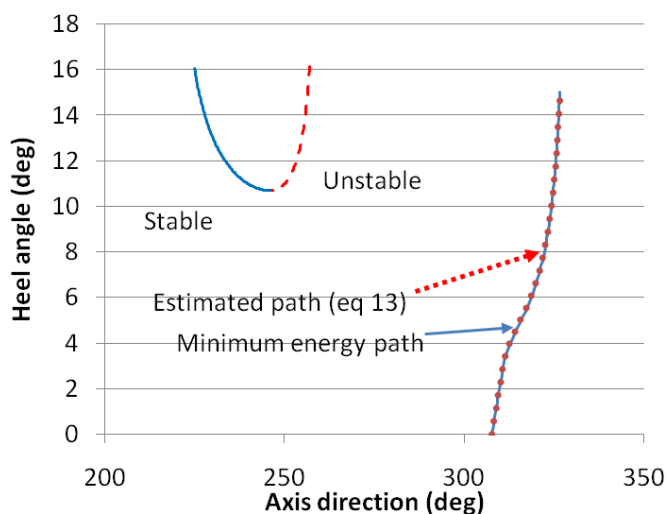

Figure 16 Axis directions for minimum energy build up, damaged

The figure also shows the estimated axis direction based on equation [12]. In this estimate, the start value at zero heel is taken from the calculations with the stability program. The other values are based on the summed increments. A very good fit is seen between the estimated and the actual axis directions.

For the damaged case, at larger heel angles, there are two paths following a local extreme in

the energy surface. For small heel angles there is only a single path.

### 8.2 Semi-submersible

Figure 17 shows a semi-submersible which at the given displacement has an intact draft of 9.106 m. Both the intact and damage condition pose a challenge when calculating the stability.

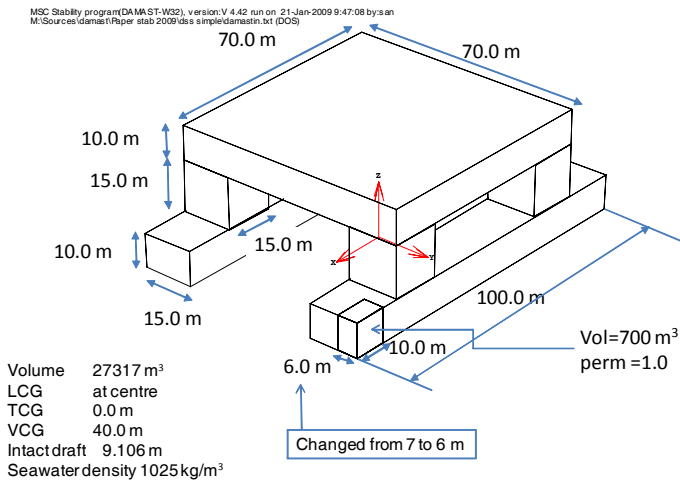

Figure 17 Shape of the semi submersible

**Intact.** Figure 18 shows the energy surface plot for the intact condition. Note that because of symmetry, the data for an axis direction of  $\alpha$  is also found for axis direction  $\alpha + 180$ . It is seen that for moderate heel angles, the minimum energy is found for an axis direction of 180 deg (and 0 deg). This is even better seen in the righting arm plot, fig 19.

When for 180 deg axis direction, heel is increased beyond 25.5 deg, the path follows a local unstable maximum instead of a local stable minimum. Instead, for larger heel angles, the minimum energy is found for axis directions of about 135 and 225 deg. A more detailed analysis can be done by looking at the twist moment depending on heel and axis direction. Figure 20 shows this as a surface plot of  $x_{cob}$  versus heel and axis direction. The locations where  $x_{cob}=0$  are those satisfying free twist. The combination of heel and axis directions for which the twist moment (or  $x_{cob}$ ) is zero are identified by the change in color in figure 20. The stable and unstable positions can

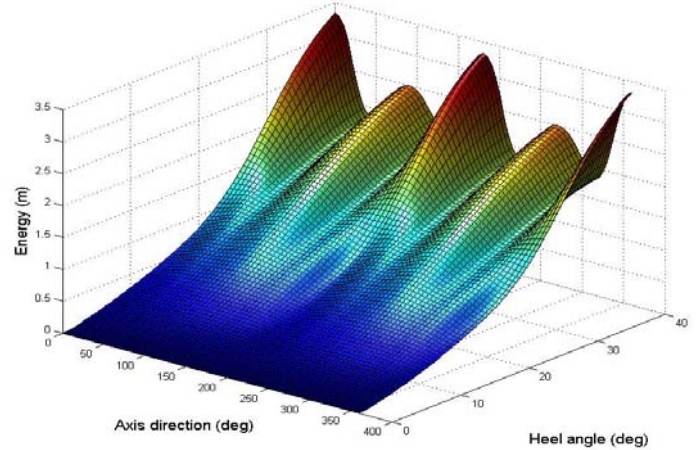

Figure 18 Energy surface, intact

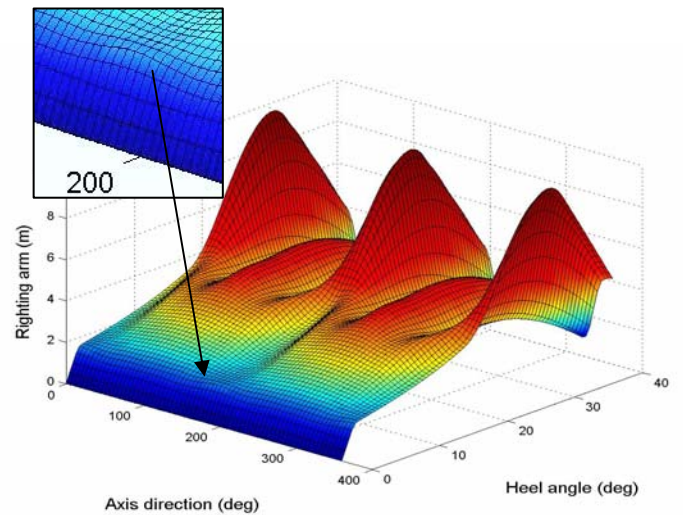

Figure 19 Surface plot of righting arm

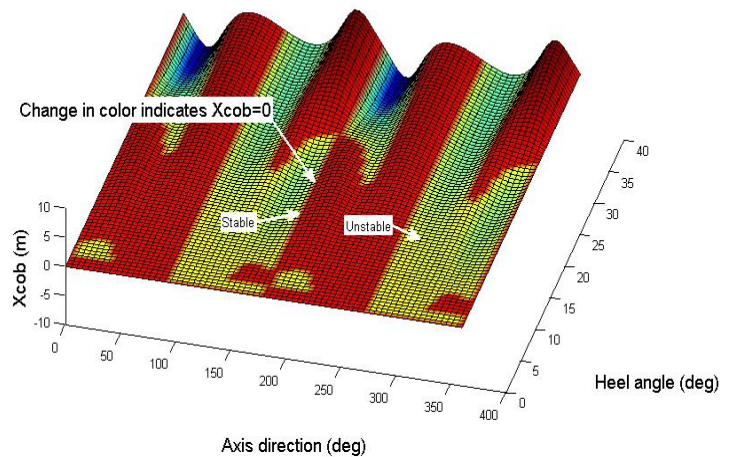

Figure 20 Surface plot of the trimming arm

be identified by looking at the slope  $dx_{cob}/d\psi$  for a given heel angle. Using this figure, the stable and unstable paths for which there is an extreme in the energy build up are as given in figure 21 for axis directions between 120 and 240 degrees.

Starting with zero heel, a gradual increase in the overturning moment will result in the rig to follow a seemingly erratic path:

heel	axis direction
0 – 1.6	180 deg
1.6 – 4.6	151-154 deg or 209 – 206 deg
4.7 – 25.4	180 deg
25.5 – 50	133-138 deg or 227 – 222 deg

At hindsight, the unstable area for very small heel angles is also seen in figure 19 by a barely noticeable hill for axis 180 and heel 4 deg.

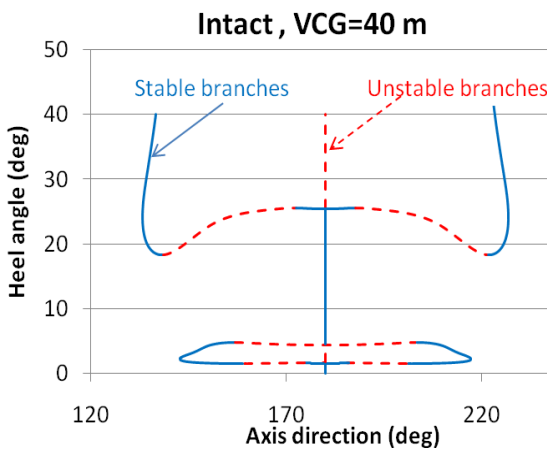

Figure 21 Stable and unstable paths

**Damaged.** When damaging the rig by removing the pontoon corner part as indicated in figure 17, the energy surface looks more simple than for the intact rig. The axis direction for minimum energy increase is around 140 deg, see fig 22. Still, also in this case, the axis direction changes considerably for increasing heel as shown in figures 22 and 23

When actually increasing the heel angle in a stepwise manner, the rig will suddenly change position when passing the 12 and 23 degrees heel, see figures 23 and 24. At 12 degrees heel, it will change from axis direction about 140 deg to about 166 degree. At 23 degree heel it

will change back to about 130 deg axis direction. Further study showed that this behavior hardly depends on the VCG.

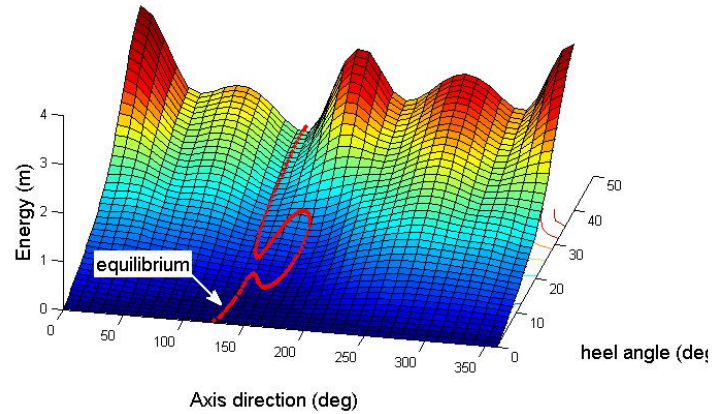

Figure 22 Energy plot, damaged

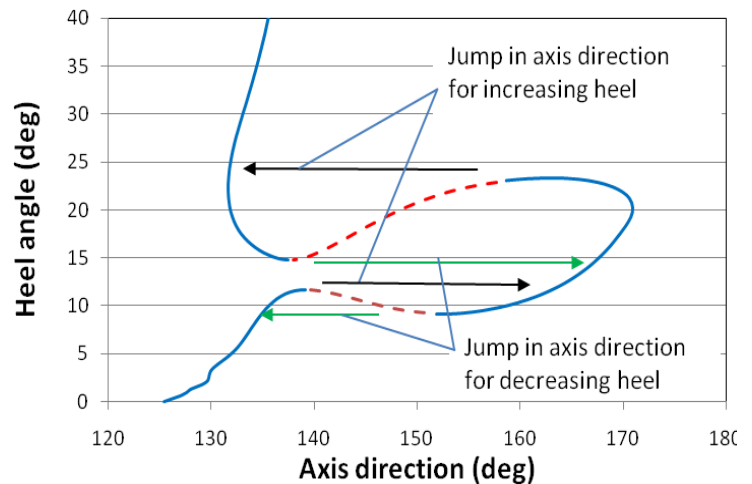

Figure 23 Relation between heel angle and axis direction, free twist

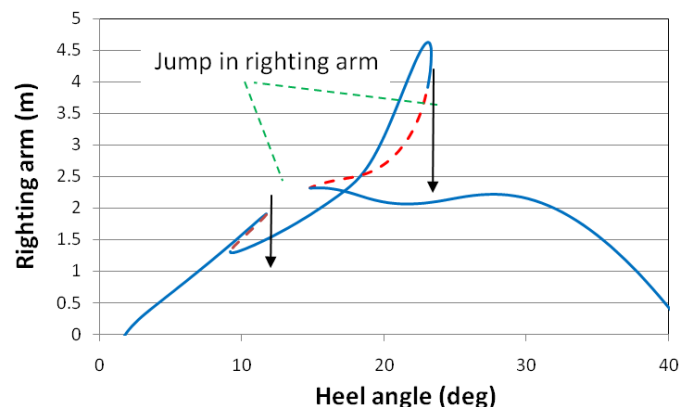

Figure 24 Righting arm following free twist

## 9. USE OF MINIMUM ENERGY PATH IN EVALUATING STABILITY CRITERIA

When evaluating stability criteria, a distinction can be made between those without and with external influence. An example of the first group is ABS's range of stability criterion for jack-ups. An example of the second group is the well known requirement on ratio between the area under the restoring moment and the wind overturning moment curves. For the first group, the minimum energy path can be followed as being the most critical, i.e. it requires the least effort to reach a particular heel angle.

For the second group, both the magnitude of the restoring moment and of the overturning moment is to be considered. This highly complicates the task of selecting the most critical heeling axis direction. When following the minimum energy path, it is relatively easy to adapt the wind overturning moment to the instantaneous axis direction. But, this still assumes that the direction of the wind overturning moment is the same as that of the restoring moment. In general, it is well possible that this is not the case *and* that the wind overturning moment has a trimming component as well. But, this raises the question is one should absorb this by letting the unit trim or if the axis direction should be modified. It is also possible that the wind overturning moment for other directions is higher and thus more governing.

Another way would be to look directly at the ratio between energy inputs versus energy build up for all axis directions without considering trim.

When including possible downflooding, the complexity of the calculation increases further.

Apart from the calculation difficulties, the major issue is the nature of the calculation. Traditionally, the effect of wind for an otherwise calm sea is looked at. The effect of waves and resulting motions can be important,

especially for a damaged structure (van Santen, 1999). Also, the calculation of the wind overturning effect is usually simplified in that the reactive force is assumed to work at the lateral center of resistance and that the forces due wind and the reactive forces do not introduce a yawing moment.

Including the effect of mooring or DP makes the analysis even more complex. In view of this, there seems to be no justification to focus on one detail whilst ignoring other effects which may be much more important.

In the end, we should not forget that the criteria are quite abstract. Being abstract, they lend themselves to consistency and reproducibility. The end results are not so much influenced by the details of the method used. As such, they fulfill the requirement of a criterion of which the evaluation is clearly defined and can be reproduced independently.

By Couser (2003) the difficulty in programming the calculation of the AVCG curves as limited by the various requirements was mentioned. The examples shown here indicate that apart from the vagueness in the criteria, the structure itself can cause problems. For the semi-submersible case at transit draft it is almost impossible to do a proper AVCG calculation. A possible way out is to use a fixed axis direction with nil trim. For a righting arm curve constructed in this way to be acceptable, it should show only modest trimming moments as this indicates that the energy depletion by letting it free to twist or trim is small.

## 10. CONCLUSIONS

1. Extending the free trim approach as used for ships to offshore units, in combination with a varying heeling axis direction, may lead to severe interpretation problems.

2. A free trim or free twist approach is sensible as this generally leads to the slowest build up of potential energy for increasing heel angle. Thus the lowest righting arm curve is

achieved. A pre-requisite is that the rig remains stable in trim and twist for the relevant range of heel angles.

3. The free twist approach with zero trim leads to the lowest gain in potential energy during heeling. This is based on both theory and data obtained from direct calculations. Thus when left free to trim and free to twist, the result is that the twist angle varies and that the trim angle remains zero.

4. Application of the lowest gain in energy approach is an unambiguous way to define the most critical or weakest axis.

5. For the determination of the critical axis direction, other effects are to be considered as well. When wind overturning is in the criterion, axes other than the weakest based on energy, may have to be considered. Also when looking at openings, other axis directions have to be looked at.

For these complex cases, it is strongly suggested to perform the calculations for *any* axis direction and with the trim fixed at zero.

**11. REFERENCES**

ABS rules for building and Classing Mobile Offshore Drilling units 2008.

Breuer, J.A. and Sjölund, K.G., 2006, “Orthogonal Tipping in Conventional Offshore Stability Evaluations”, Proceedings of the 9<sup>th</sup> International conference on Stability of Ships and Ocean Vehicles (STAB 2006).

Santen, J.A., 1986, “Stability calculations for jack-ups and semi-submersibles”, Conference on computer Aided. Design, Manufacturer and Operation in the Marine and Offshore Industries CADMO 1986, Washington.

Santen, J.A., 1999, “Jack-up model tests for dynamic effects on intact and damaged

stability”, Seventh International Conference The Jack-up Platform: Design, Construction and Operation, City University, London, September.

Witz, J.A., Patel, M.H., July 1985, “A pressure integration technique for hydrostatic analysis”, RINA supplementary papers, Vol. 127.

Couser, P., “A Software Developer’s Perspective of Stability Criteria”, 8<sup>th</sup> International Conference on the Stability of Ships and Ocean Vehicles, STAB 2003

**12. NOMENCLATURE**

$\Delta$	=	displacement (t)
$\phi$	=	heel angle
$\psi$	=	axis direction (twist angle)
$\theta$	=	trim angle
$C_{xy}$	=	cross moment of the waterline plane for rotation around its centre $\approx \int x.y.dA$
CoB	=	Centre of Buoyancy
CoG	=	Centre of gravity
E	=	potential energy divided by displacement
$GM_L$	=	metacentric height for trim at a particular heel angle
$GM_T$	=	metacentric height for heel at a particular heel angle
$M_x$	=	moment around the longitudinal horizontal axis divided by displacement
$M_y$	=	moment around the transverse horizontal y axis divided by displacement
VCB	=	vertical centre of buoyancy above the centre of gravity
x	=	horizontal axis along the initial heeling axis, forward positive
$x_{cob}, y_{cob}$	=	location centre of buoyancy relative to CoG
y	=	horizontal axis perpendicular to the x axis (right handed system)